

INSTRUCTION MANUAL

MODEL #BB-22 PROFESSIONAL

REMOTE COOKING THERMOMETER

Introduction

Congratulations on your purchase of the Professional Remote Cooking Thermometer, a programmable radio frequency food thermometer. You will now be able to remotely monitor the time and temperature of food cooking on your grill from anywhere, even in your home.

Components

- 1 - receiver unit
- 1 - transmitter unit
- 1 - detachable stainless steel probe sensor

Receiver Features

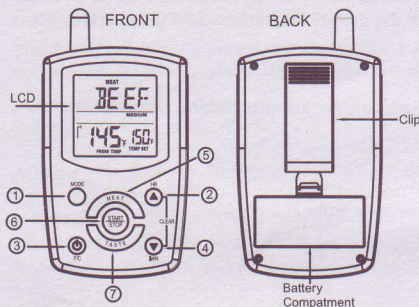

LCD (Liquid Crystal Display) – Displays all icons, temperature and timer. The backlight will flash Blue once the temperature increases 10F, will change to Green when the temperature is within 15F of the set temperature and will turn Red when it reaches the set temperature. See LCD diagram for detailed information.

CLIP – Battery compartment clip allows you to be mobile. Clip the receiver unit to belt.

BATTERY COMPARTMENT – Holds 2 AAA batteries.

Buttons

- MODE** – Press to select thermometer or timer mode. Press & hold for 2 seconds to register with the transmitter.
- HR** – In timer mode, press to set hour. Press & hold for 2 seconds, the hours will increase 10 hours per second. In thermometer mode, press to increase the temperature value. Press & hold for 2 seconds, the temperature value will increase 10 degrees per second.
- ON-OFF/°F-°C** – Press and hold for 2 seconds turns receiver functions on and off. In thermometer mode press to select temperature readings in Celsius or Fahrenheit.
- MIN** – In timer mode, press to set minutes. Press & hold for 2 seconds, the minutes will increase 10 minutes per second. In thermometer mode, press to decrease the temperature value. Press & hold for 2 seconds, the temperature value will decrease 10 degrees per second.
- MEAT** – In thermometer mode, press to select meat type, PROG (program), GBEEF (ground beef), GPOUL (ground poultry), BEEF, VEAL, CHCKE (chicken), PORK, POULT (poultry), LAMB & FISH. In Timer mode switches between hour/minute timer to a minute/second timer and back.
- START STOP** – In timer mode, press to start or stop the timer.
- TASTE** – In thermometer mode, select the meat taste level, RARE, MED RARE, MEDIUM, MED WELL and WELL DONE.

LCD

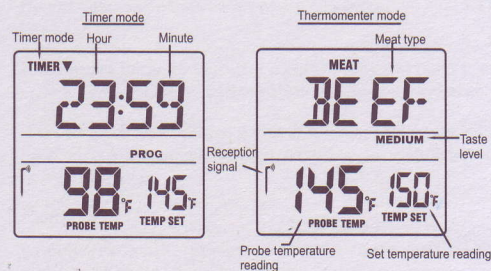

Transmitter Features

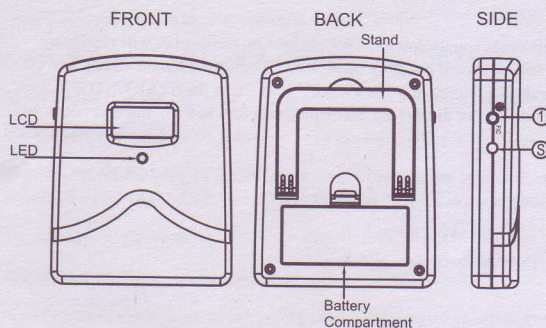

Stand – Fold up stand for easy storage.

BATTERY COMPARTMENT – holds 2 AAA batteries.

S – plug in for stainless steel probe sensor

Buttons

1. ON-OFF/°F-°C – Press and hold for 2 seconds turns transmitter on and off. Press to select temperature readings in Celsius or Fahrenheit.

Registration Procedures

Open the battery compartment of receiver and insert the two “AAA” batteries. Open the battery compartment of transmitter and insert the two “AAA” batteries.

The Professional Remote Cooking Thermometer needs the receiver to register the radio frequency signal from the transmitter.

Transmitter & Receiver are off.

1. Plug the stainless steel probe sensor into the plug in of the transmitter.
2. Turn transmitter on by pressing and holding the ON-OFF/°F-°C button on the side for 2 seconds.
3. Turn the receiver on by pressing and holding the ON-OFF/°F-°C button for 2 seconds.
4. Registration is complete when the receiver shows the probe temperature where the “---” was.

Auto Off feature:

The receiver will turn off automatically if it hasn't receive the temperature signal from the transmitter for more than 30 minutes or the temperature received is always lower than 50 C (122F) in 30 minutes. However, the Auto Off feature will be automatically disabled if the timer is running.

The transmitter will turn off automatically if the temperature measured is always lower than 50 C (122F) in 30 minutes.

Measure meat temperature to USDA doneness temperature range

1. Press MODE to select thermometer mode. The upper display will show a small MEAT and a meat type such as BEEF.
2. Press MEAT to select meat type. PROG (program), GBEEF (ground beef), GPOUL (ground poultry), BEEF, VEAL, CHCKE (chicken), PORK, POULT (poultry), LAMB & FISH.
3. Press TASTE to select the level of doneness for the meat type selected. RARE, MED RARE, MEDIUM, MED WELL and WELL DONE.

Note: The temperature displayed to the right of the actual meat temperature PROBE TEMP will show the preset temperature TEMP SET according to USDA doneness levels. Example: Beef will be Well Done at 165 °F.

4. Once the temperature of meat reaches the preset doneness level the receiver will beep and the LCD backlight will turn red.

Measure meat temperature set to your specific taste

1. Press MODE to select thermometer mode. The upper display will show a small MEAT and a meat type such as BEEF.
2. Press HR or MIN to raise or lower the set temperature. As you press HR or Min the display changes to PROG (program). Holding the button will raise or lower the temperature setting rapidly. Pressing MEAT will return you to the preset USDA ranges.
3. Once the temperature of meat reaches the preset doneness level the receiver will beep and the LCD backlight will turn red.

Using the Timer

Count down

1. Press MODE to select timer mode. The upper display will show a small TIMER and 0:00.
2. Press HR and MIN button to set the timer. Press START/STOP button to start countdown. “▼” will blink for every second.

3. To stop the countdown process , press START/STOP button. The “▼” becomes solid.
4. Press HR & MIN buttons together to clear the setting back to 0:00.

Note: The minimum setting for the timer is 1 minute. When the timer counts down below 1 hour 1:00 the display will change to 59'59" display advising 59 minutes 59 seconds. The seconds will be shown counting down then. When the countdown reaches 0'00" the timer starts counting up and it will beep for 60 seconds. The timer and “▲▼” will blink. Press the START/STOP button to stop beeping. When the count up reaches 23:59:59 (59 seconds are not displayed) the display will turn to 0:00, the unit beeps and “▲▼” will blink for 60 seconds.

Count up

1. Press MODE to select timer mode. The upper display will show a small TIMER and 0:00.
2. Press START/STOP button to start count up. The “▲” will blink for every second.
3. To stop the count up process , press START/STOP button. The “▲” becomes solid.
4. Press CLEAR button to clear the setting back to 0:00.

Procedure for typical use on an outdoor grill:

The following typical example will go through the steps to have the Professional Remote Cooking Thermometer alert you to when a beef steak is cooked to medium (USDA doneness level) and remind you to rotate hot dogs in 5 minutes.

1. Turn on the grill.
2. Follow the registration procedure.
3. Place steak and hot dogs on grill rack.
4. Insert probe sensor into the center of thickest portion of the steak. Avoid touching bone or heavy fat areas. Assume the meat temperature is 45 °F.
5. Position the probe sensor wire so they will not come into contact with flames and exit the grill surface area without being pinched/crushed by the grill cover.
6. Stand the transmitter away from heat source of grill. DO NOT put transmitter on closed cover or under the cover. The transmitter is not waterproof DO NOT use in the rain.
7. Press MEAT so BEEF is displayed.
8. Press TASTE so MEDIUM is displayed and 150 °F will be shown as the TEMP SET.
9. Press MODE to change to timer mode.
10. Press MIN 5 times to set for 5 minutes so that 0:05 is displayed. Press START/STOP to start the countdown. Press MODE to go back to thermometer mode.
11. Clip the receiver to your belt or pocket and move up to 100 ft away from the outdoor grill. Go indoors if desired.
12. When 5 minutes are up the receiver will beep for 60 seconds.
13. When the temperature of probe in the steak reaches 55 °F the LCD backlight will flash blue.
14. When the temperature of probe in the steak reaches 135 °F the LCD backlight will flash green.
15. When the temperature of probe in the steak reaches 150 °F MEDIUM the receiver will beep and the LCD backlight will flash red.
16. Press STOP to turn off the alert.
15. Turn off grill. Remove the probe sensor from steak. Always wear a heat resistant glove to touch the stainless steel probe sensor or wire during or just after cooking. Do not touch with bare hands.
16. Clean the stainless steel probe and dry thoroughly after each and every use.
17. Turn off the transmitter.

HELPFUL HINTS

If the receiver and/or the transmitter display LLL or HHH instead of the probe temperature, wait for probe to reach room temperature. If LLL or HHH is still displayed it is likely the internal probe wire has shorted out either through moisture or heat damage.

Do not immerse the probe in water while cleaning.

Do not allow the probe or probe wire to come into contact with flames. If cooking with grill cover closed, only use medium or low heat.

If the probe becomes defective within 90 day warranty period please return defective probe to address below along with return address and we will send you new probe no charge.

If the temperature displayed seems to read too high or the temperature seems to increase too quickly check to make sure the probe tip is not poking through the food to outside. Reposition the probe tip in the center of the thickest part of food. Avoid touching bone or heavy fat areas.

Cautions:

Always wear a heat resistant glove to touch the stainless steel probe sensor or wire during or just after cooking. Do not touch with bare hands.

Keep the stainless steel probe sensor and wire away from children.

Not Intended for Use by Persons ages 12 and Under

Clean the stainless steel probe and dry thoroughly after each and every use.

Do not immerse the probe or wire in water. Clean using a damp, soapy cloth.

Do not use the receiver or transmitter in the rain. They are not waterproof.

Do not expose the plug of the stainless steel probe or the plug in hole of the transmitter to water or any liquid. This will result in a bad connection and faulty readings.

Do not expose the receiver or transmitter to direct heat or surface.

Do not use stainless steel probe in microwave oven.

The Professional Remote Cooking Thermometer registers temperatures as low as 14 °F (-10 °C) and as high 482 °F (250 °C). LLL will be displayed below 14 °F and HHH will be displayed above 410 °F. Do not use the stainless steel probe sensor above 482 °F. Doing so will deteriorate the wire.

Cleaning

Always wear a heat resistant glove to touch the stainless steel probe sensor or wire during or just after cooking. Do not touch with bare hands.

Keep the stainless steel probe sensor and wire away from children.

Wash the metal probe tip with hot soapy water and dry thoroughly. Do not immerse the probe in water while cleaning.

Wipe the transmitter and receiver with damp cloth. Do not immerse either in water.

LIMITED NINETY DAY WARRANTY

Maverick Industries Inc. warrants the Professional Remote Cooking Thermometer to be free of defects in parts, materials and workmanship for a period of 90 days, from date of purchase. Should any repairs or servicing under this warranty be required, contact Maverick Customer Service by mail or phone for instructions on how to pack and ship the Professional Remote Cooking Thermometer to Maverick's National Service Center located as follows:

Maverick Customer Service
94 Mayfield Ave.
Edison NJ 08837

www.maverickhousewares.com

Telephone: (732) 417-9666

Hours: Weekdays 8:30 AM- 4:30 PM

Do not send any parts or product to Maverick without calling and obtaining a Return Authorization Number and instructions.

This warranty is VOID if instructions for use are not followed; for accidental damage; for commercial use; for damage incurred while in transit; or if the Professional Remote Cooking Thermometer has been tampered with.

This warranty gives you specific legal rights and you may also have other rights which vary from state to state.

Replacement Probes

To purchase, out of warranty, stainless steel replacement probes please mail us a check to the address below and specify probe type:

BB-22 Probe \$12.00/ea

All prices include shipping & handling. NJ residents add 7% sales tax.

Attn Customer Service
Maverick Industries, Inc.
94 Mayfield Ave.
Edison NJ 08837